

Application:	Rechargeable battery packs Lithium cell and battery packs
Product Features:	Low profile, Solid stat
Operation Current:	1.9A~7.3 A
Maximum Voltage:	15V& 20V
Temperature Range:	-40°C to 85°C
Agency Recognition:	UL, C-UL, TÜV

Electrical Characteristics (23°C)

Part Number	Hold Current	Trip Current	Rated Voltage	Maximum Current	Typical Power	Resistance Tolerance		
						RMIN	RMAX	R1MAX
						IH, A	IT, A	VMAX, Vdc
LR190-15	1.9	3.9	15	100	1.2	0.039	0.072	0.102
LR260-15	2.6	5.8	15	100	2.5	0.020	0.042	0.063
LR380-15	3.8	8.3	15	100	2.5	0.013	0.026	0.037
LR450-20	4.5	8.9	20	100	2.5	0.011	0.020	0.028
LR550-20	5.5	10.5	20	100	2.8	0.009	0.016	0.022
LR600-20	6.0	11.7	20	100	2.8	0.007	0.014	0.019
LR730-20	7.3	14.1	20	100	3.3	0.006	0.012	0.015

IH=Hold current-maximum current at which the device will not trip at 23°C still air.
 IT=Trip current-minimum current at which the device will always trip at 23°C still air.
 V MAX=Maximum voltage device can withstand without damage at its rated current.
 I MAX= Maximum fault current device can withstand without damage at rated voltage (V max).
 Pd=Typical power dissipated from device when in the tripped state in 23°C still air environment.
 RMIN=Minimum device resistance at 23°C.
 R1MAX=Maximum device resistance at 23°C, 1 hour after tripping .
 Lead material:0.13mm.nominal thickness ,quarter-hard nickel.
 Insulating material: Polyester tape.

LR Product Dimensions (Millimeters)

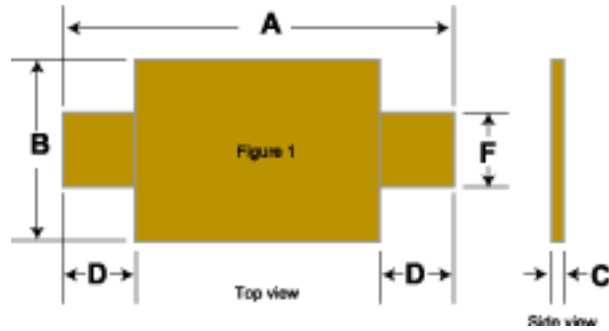

Part Number	A		B		C		D		F	
	Min	Max	Min	Max	Min	Max	Min	Max	Min	Max
LR190-15	19.9	22.1	4.9	5.5	0.6	1.0	5.5	7.5	3.9	4.1
LR260-15S	20.9	23.1	4.9	5.5	0.6	1.0	4.1	5.5	3.9	4.1
LR380-15	24.0	26.0	6.9	7.5	0.6	1.0	4.1	5.5	4.9	5.1
LR450-20	24.0	26.0	9.9	10.5	0.6	1.0	5.3	6.7	5.9	6.1
LR550-20	35.0	37.0	6.9	7.5	0.6	1.0	5.3	6.7	4.9	5.1
LR600-20	24.0	26.0	13.9	14.5	0.6	1.0	4.1	5.5	5.9	6.1
LR730-20	27.1	29.1	13.9	14.5	0.6	1.0	4.1	5.5	5.9	6.1

Thermal Derating Curve

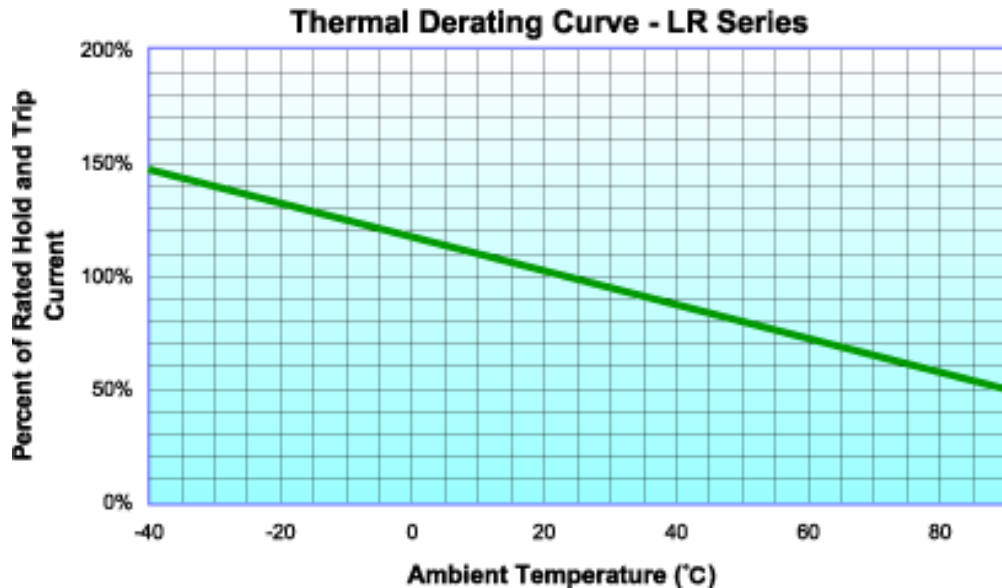

Typical Time-To-Trip at 23°C

A=LR190-15
 B=LR260-15
 C=LR380-15
 D=LR450-20
 E=LR550-20
 F=LR600-20
 G=LR730-20

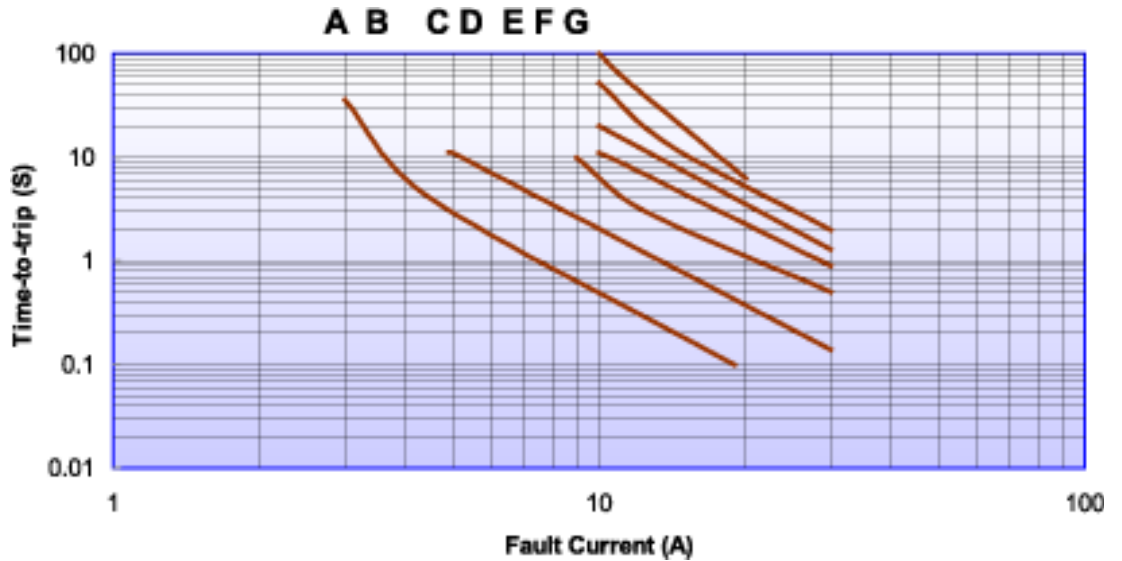

Part Numbering System

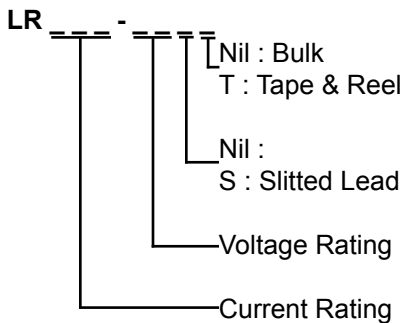

Part Marking System

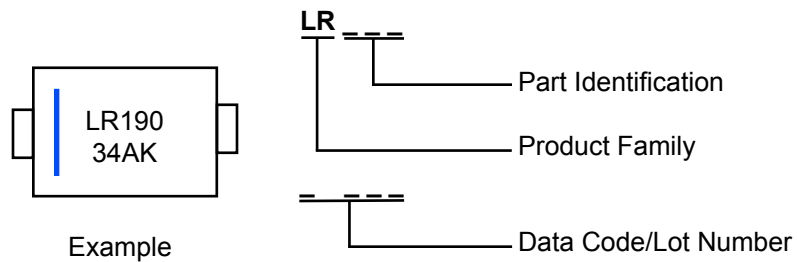

Standard Package

P/N	Pcs /Bag
LR190-15	1K
LR260-15	1K
LR380-15	1K
LR450-20	500
LR550-20	500
LR600-20	500
LR730-20	500

- 1- Operation beyond the specified maximum ratings or improper use may result in damage and possible electrical arcing and/or flame.
- 2 -PPTC device are intended for occasional overcurrent protection. Application for repeated overcurrent condition and/or prolonged trip are not anticipated.
- 3- Avoid contact of PPTC device with chemical solvent. Prolonged contact will damage the device performance.