



RT Series

Radial Leaded PTC



Application:	IEEE 1394 Firewire, computers & consumer electronics.
Product Features:	Fast trip time, lower trip-to-hold ratio, radial-leaded product ideal for up to 36V.
Operation Current:	500mA ~ 2.50A
Maximum Voltage:	36V
Temperature Range:	-40°C to 85°C
Agency Recognition:	UL, C-UL

Electrical Characteristics (23°C)

Part Number	Hold Current	Trip Current	Maximum Current	Rated Voltage	Typical Power	Resistance Tolerance	
						RMIN	R1MAX
	IH, A	IT, A	IMAX, A	VMAX, Vdc	Pd, W	ohms	ohms
RT050-36	0.50	1.10	40	36	0.67	0.140	0.448
RT075-36	0.75	1.50	40	36	0.71	0.115	0.368
RT090-36	0.90	1.80	40	36	0.74	0.090	0.288
RT120-36	1.20	2.30	40	36	0.78	0.074	0.180
RT135-36	1.35	2.50	40	36	0.84	0.059	0.143
RT160-36	1.60	2.75	40	36	0.86	0.041	0.131
RT190-36	1.90	3.00	40	36	0.90	0.045	0.092
RT220-36	2.20	3.50	40	36	0.95	0.025	0.080
RT250-36	2.50	4.00	40	36	0.99	0.020	0.064

IH=Hold current-maximum current at which the device will not trip at 23°C still air.

IT=Trip current-minimum current at which the device will always trip at 23°C still air.

V MAX=Maximum voltage device can withstand without damage at its rated current.

I MAX= Maximum fault current device can withstand without damage at rated voltage (V max).

Pd=Typical power dissipated from device when in the tripped state in 23°C still air environment.

RMIN=Minimum device resistance at 23°C.

R1MAX=Maximum device resistance at 23°C, 1 hour after tripping .

Physical specifications:

Lead material: Tin plated copper, 24 AWG.

Soldering characteristics: MIL-STD-202, Method 208E.

Insulating coating:Flame retardant epoxy, meet UL-94V-0 requirement.



RT Product Dimensions (Millimeters)

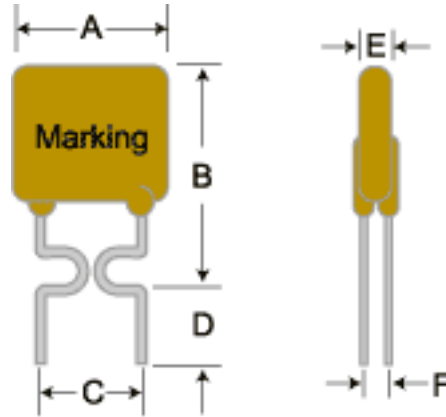

Part Number	A	B	C	D	E	F
	Maximum	Maximum	Typical	Minimum	Maximum	Typical
RT050-36	7.4	12.2	5.1	7.6	3.0	1.1
RT075-36	7.4	12.2	5.1	7.6	3.0	1.1
RT090-36	7.4	12.2	5.1	7.6	3.0	1.1
RT120-36	7.4	12.2	5.1	7.6	3.0	1.1
RT135-36	7.4	14.2	5.1	7.6	3.0	1.1
RT160-36	7.4	14.0	5.1	7.6	3.0	1.1
RT190-36	9.0	13.5	5.1	7.6	3.0	1.1
RT220-36	10.0	17.0	5.1	7.6	3.0	1.1
RT250-36	10.0	19.5	5.1	7.6	3.0	1.1

Thermal Derating Curve

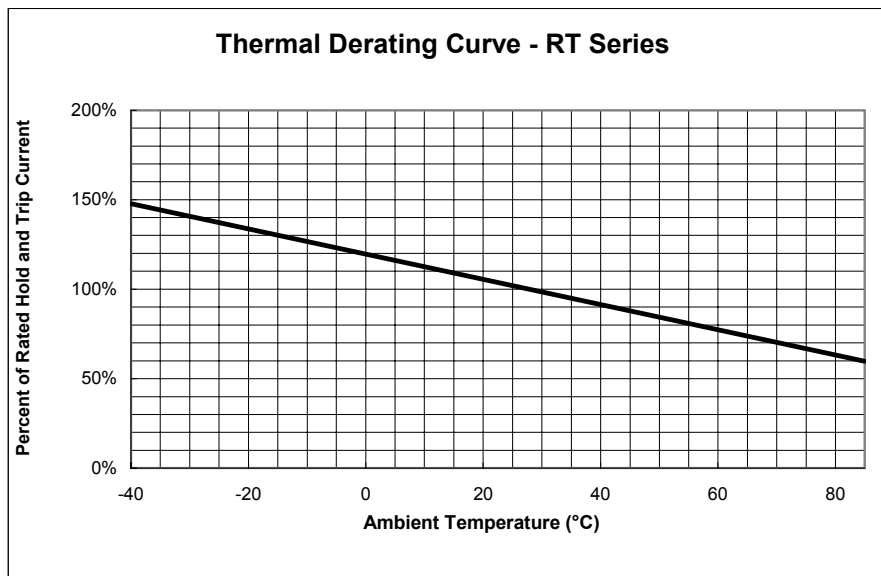

Typical Time-To-Trip at 23°C

- A = RT050-36
- B = RT075-36
- C = RT090-36
- D = RT120-36
- E = RT135-36
- F = RT160-36
- G = RT190-36
- H = RT220-36
- I = RT250-36

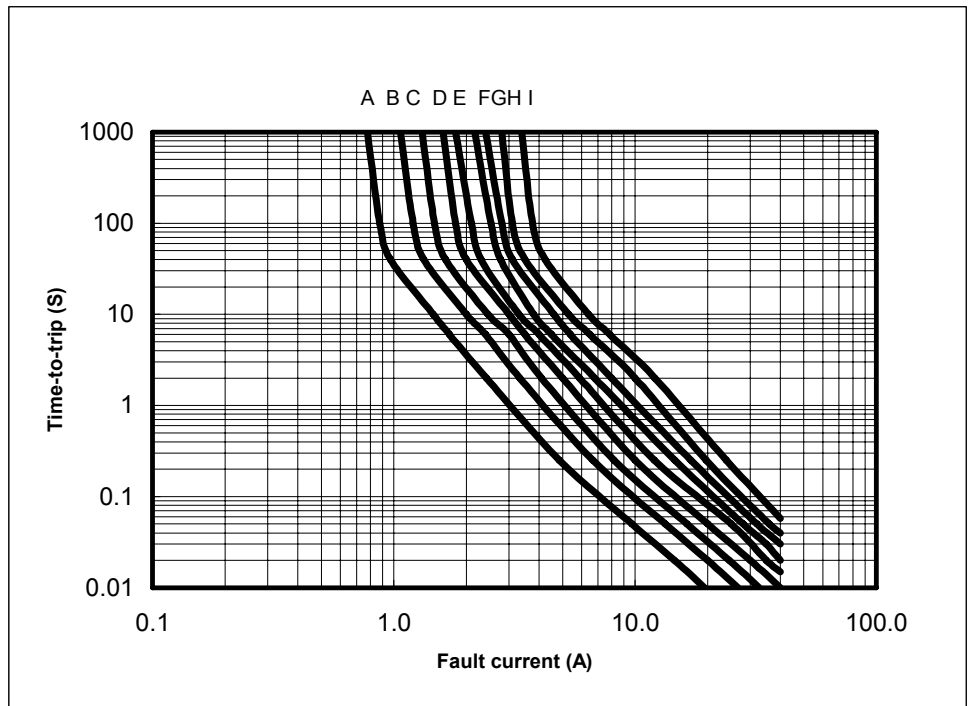

Material Specification

- Lead material: Tin plated copper, 24 AWG.
- Soldering characteristics: MIL-STD-202, Method 208E.
- Insulation coating: Flame retardant epoxy, meets UL-94V-0 requirement.

Part Numbering System

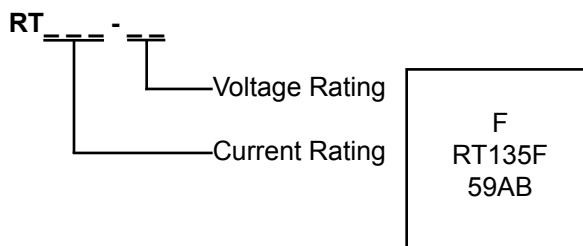

Part Marking System

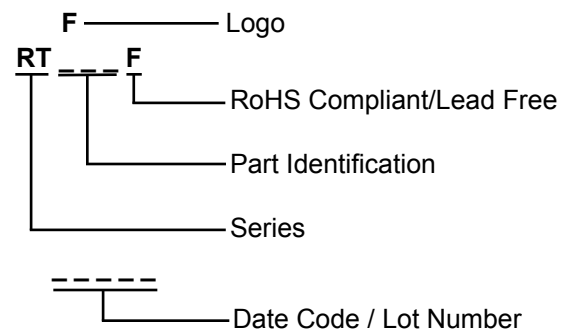

- 1- Operation beyond the specified maximum ratings or improper use may result in damage and possible electrical arcing and/or flame.
- 2 -PPTC device are intended for occasional overcurrent protection. Application for repeated overcurrent condition and/or prolonged trip are not anticipated.
- 3- Avoid contact of PPTC device with chemical solvent. Prolonged contact will damage the device performance.